

PARTS DETAILS

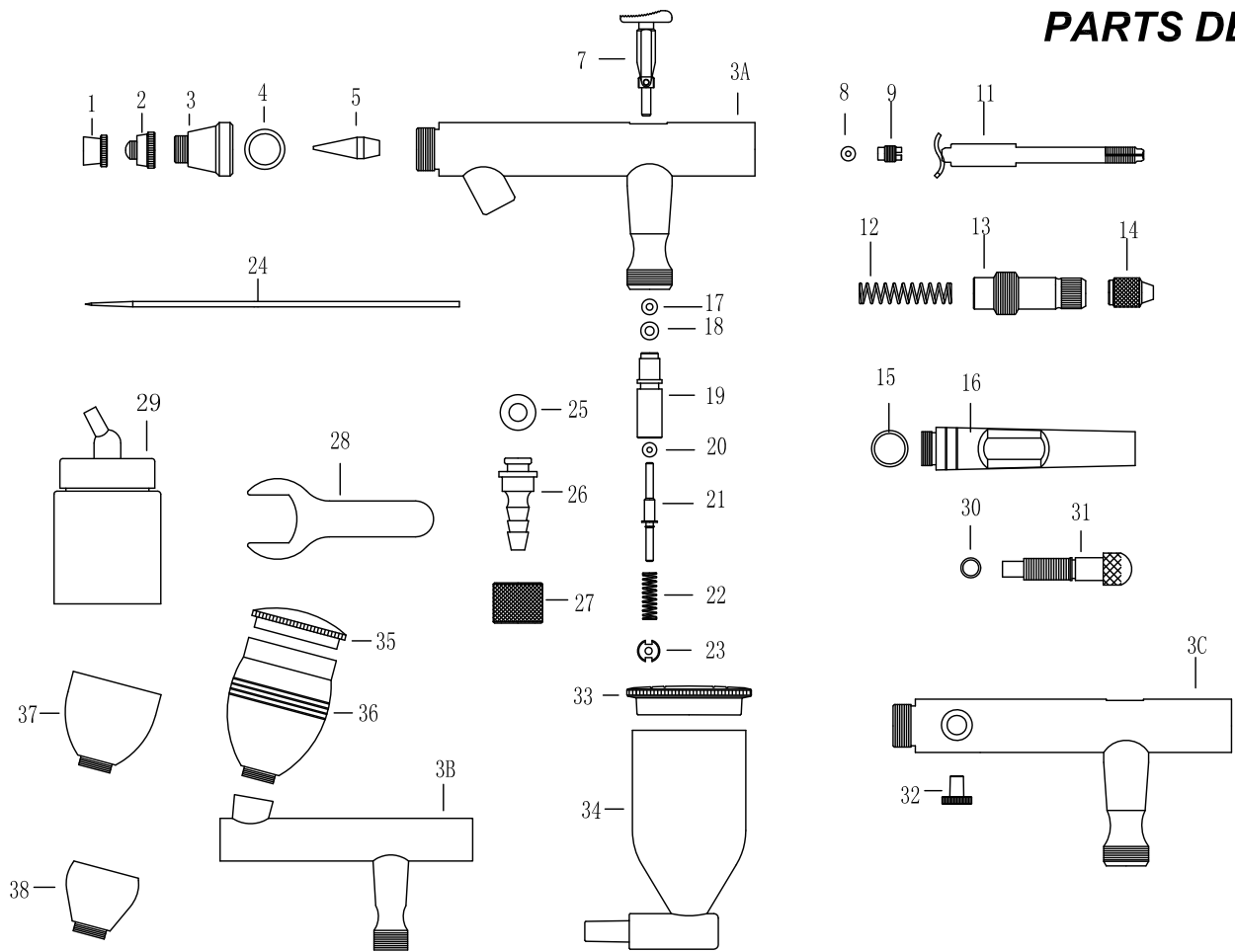

S62

G33

SB88

| # | Part Description | Part# | S62 | G33 | SB88 |
|----|---------------------------|-------|-----|-----|------|
| 1 | Needle Cap | | ■ | ■ | ■ |
| 2 | Nozzle Cap | 0.3 | ■ | ■ | ■ |
| | | 0.5 | × | ■ | ■ |
| | | 0.8 | × | ■ | ■ |
| 3 | Head Cap | | ■ | ■ | ■ |
| 4 | O-Ring | | ■ | ■ | ■ |
| 5 | Nozzle | 0.3 | ■ | ■ | ■ |
| | | 0.5 | × | ■ | ■ |
| | | 0.8 | × | ■ | ■ |
| 3A | Airbrush Body | | ■ | × | × |
| 3B | Airbrush Body | | × | ■ | × |
| 3C | Airbrush Body | | × | × | ■ |
| 7 | Operation Lever | | ■ | ■ | ■ |
| 8 | O-Ring for Needle Guide | | ■ | ■ | ■ |
| 9 | Needle Guide | | ■ | ■ | ■ |
| 11 | Needle Chucking Guide | | ■ | ■ | ■ |
| 12 | Spring | | ■ | ■ | ■ |
| 13 | Spring Case | | ■ | ■ | ■ |
| 14 | Needle Chucking Net | | ■ | ■ | ■ |
| 15 | O-Ring | | ■ | ■ | ■ |
| 16 | Standard-Handle Adjusting | | ■ | ■ | ■ |
| 17 | O-Ring | | ■ | ■ | ■ |
| 18 | O-Ring | | ■ | ■ | ■ |
| 19 | Air valve Guide Body | | ■ | ■ | ■ |
| 20 | Valve Rod O-Ring | | ■ | ■ | ■ |
| 21 | Valve Rod | | ■ | ■ | ■ |
| 22 | Valve Spring | | ■ | ■ | ■ |
| 23 | Valve Screw | | ■ | ■ | ■ |
| 24 | Needle | 0.3 | ■ | ■ | ■ |
| | | 0.5 | × | ■ | ■ |
| | | 0.8 | × | ■ | ■ |
| 25 | O-Ring for Hose Connector | | ■ | ■ | ■ |
| 26 | Hose Connector | | ■ | ■ | ■ |
| 27 | Hose Connector Nut | | ■ | ■ | ■ |
| 28 | Head Cap Spanner | | ■ | ■ | ■ |
| 29 | 22 cc Glass jar assembly | | ■ | × | × |
| 30 | O-Ring | | ■ | ■ | ■ |
| 31 | Adjusting Screw | | ■ | ■ | ■ |
| 32 | Plug | | × | × | ■ |
| 33 | Lid for Color Cup | | × | × | ■ |
| 34 | Color Cup | | × | × | ■ |
| 35 | Lid for Color Cup | | × | ■ | × |
| 36 | Color Cup (13ml) | | × | ■ | × |
| 37 | Color Cup (5ml) | | × | ■ | × |
| 38 | Color Cup (2ml) | | × | ■ | × |